



Designation: D6234 – 13 (Reapproved 2020)

Standard Test Method for Shake Extraction of Mining Waste by the Synthetic Precipitation Leaching Procedure¹

This standard is issued under the fixed designation D6234; the number immediately following the designation indicates the year of original adoption or, in the case of revision, the year of last revision. A number in parentheses indicates the year of last reapproval. A superscript epsilon (ϵ) indicates an editorial change since the last revision or reapproval.

1. Scope

1.1 This test method covers a procedure for the shake leaching of mining waste containing at least 80 % dry solids (≤ 20 % moisture) in order to generate a solution to be used to determine the inorganic constituents leached under the specified testing conditions that conform to the synthetic precipitation leaching procedure (SPLP).

1.2 This test method calls for the shaking of a known weight of mining waste with acidic extraction fluid of a specified composition, as well as the separation of the liquid phase for analysis. The pH of the extraction fluid is to reflect the pH of acidic precipitation in the geographic region in which the waste being tested is to be disposed.

NOTE 1—Possible sources of information concerning the pH of the precipitation in the geographic region of interest include state and federal environmental agencies, state universities, libraries, etc. pH values given in USEPA Method 1312, that are 4.2 east of the Mississippi River and 5.0 west of the Mississippi River and are based on acid precipitation maps, are examples of values that can be used. If the pH of the laboratory water is less than the desired pH for the site, do not use this test method; use Practice [D3987](#) or Test Method [E2242](#).

NOTE 2—The method may also be suitable for use in testing of mineral processing waste from metal mining process operations for jurisdictions that do not require the use of Test Method [E2242](#).

1.3 This test method is intended to describe the procedure for performing single batch extractions only. It does not describe all types of sampling, sample preservation, and analytical requirements that may be associated with its application.

1.4 The values stated in SI units are to be regarded as the standard. No other units of measurement are included in this standard.

1.5 *This standard does not purport to address all of the safety concerns, if any, associated with its use. It is the responsibility of the user of this standard to establish appropriate*

appropriate safety, health, and environmental practices and determine the applicability of regulatory limitations prior to use.

1.6 *This international standard was developed in accordance with internationally recognized principles on standardization established in the Decision on Principles for the Development of International Standards, Guides and Recommendations issued by the World Trade Organization Technical Barriers to Trade (TBT) Committee.*

2. Referenced Documents

2.1 *ASTM Standards:*²

[D75/D75M Practice for Sampling Aggregates](#)

[D420 Guide for Site Characterization for Engineering Design and Construction Purposes](#)

[D653 Terminology Relating to Soil, Rock, and Contained Fluids](#)

[D1129 Terminology Relating to Water](#)

[D1193 Specification for Reagent Water](#)

[D2234/D2234M Practice for Collection of a Gross Sample of Coal](#)

[D2777 Practice for Determination of Precision and Bias of Applicable Test Methods of Committee D19 on Water](#)

[D3370 Practices for Sampling Water from Flowing Process Streams](#)

[D3987 Practice for Shake Extraction of Solid Waste with Water](#)

[D5744 Test Method for Laboratory Weathering of Solid Materials Using a Humidity Cell](#)

[E691 Practice for Conducting an Interlaboratory Study to Determine the Precision of a Test Method](#)

[E877 Practice for Sampling and Sample Preparation of Iron Ores and Related Materials for Determination of Chemical Composition and Physical Properties](#)

[E1915 Test Methods for Analysis of Metal Bearing Ores and Related Materials for Carbon, Sulfur, and Acid-Base Characteristics](#)

[E2242 Test Method for Column Percolation Extraction of Mine Rock by the Meteoric Water Mobility Procedure](#)

¹ This test method is under the jurisdiction of ASTM Committee [D34](#) on Waste Management and is the direct responsibility of Subcommittee [D34.01.04](#) on Waste Leaching Techniques.

Current edition approved Sept. 1, 2020. Published September 2020. Originally approved in 1998. Last previous edition approved in 2013 as D6234 – 13. DOI: 10.1520/D6234-13R20.

² For referenced ASTM standards, visit the ASTM website, www.astm.org, or contact ASTM Customer Service at service@astm.org. For *Annual Book of ASTM Standards* volume information, refer to the standard's Document Summary page on the ASTM website.

2.2 EPA Document:³

U.S. Environmental Protection Agency, Synthetic Precipitation Leaching Procedure, Method 1312 in SW-846, Test Methods for Evaluating Solid Waste, Physical/Chemical Methods, Third Edition

3. Terminology

3.1 *Definitions*—For definitions of terms used in this test method, see Terminology **D1129**.

3.2 *Definitions of Terms Specific to This Standard:*

3.2.1 *mining waste, n*—overburden or waste rock excavated and disposed of during mining operations.

3.3 *Symbols*—Variables listed in this test method are defined in the individual sections in which they are discussed.

4. Significance and Use

4.1 This test method is intended as a means for obtaining an extract of mining waste. The extract may be used to estimate the release of certain inorganic constituents of the waste under the laboratory conditions described in this test method. The user is advised to minimize the holding time between sampling and testing if the waste is suspected to contain reactive sulfide minerals.

NOTE 3—This method is not intended to be used as a kinetic test to simulate weathering of mining wastes. For kinetic testing of mining wastes, refer to Test Method **D5744** to determine release rates for constituents of interest. For static testing of metal mining ore and mining or mineral processing waste materials, refer to Test Methods **E1915**.

4.2 The pH of the extraction fluid used in this test method is to reflect the pH of acidic precipitation in the geographic region in which the waste being tested is to be disposed (see **1.2**).

4.3 An intent of this test method is for the final pH of the extract to reflect the interaction of the extractant with the buffering capacity of the waste.

4.4 This test method is not intended to provide an extract that is representative of the actual leachate produced from a waste in the field or to produce extracts to be used as the sole basis of engineering design. If the conditions of this test method are not suitable for the test material, USEPA Method 1312 or Test Method **E2242** may be used.

4.5 This test method has not been demonstrated to simulate actual disposal site leaching conditions.

4.6 This test method produces extracts that are amenable to the determination of both major and minor (trace) inorganic constituents. When minor constituents are being determined, it is especially important that precautions be taken in sample storage and handling to avoid possible contamination of the samples.

4.7 This test method has been tested to determine its applicability to certain inorganic components in the waste. This test method has not been tested for applicability to organic substances, volatile matter (see **Note 5**), or biologically active

samples. This test method has undergone limited testing to determine its reproducibility.

5. Apparatus

5.1 *Straightedge*, such as a thin-edged yardstick.

5.2 *Impermeable Sheet*, of glazed paper, oil cloth, or other flexible material of a composition suitable to the analytes of interest.

5.3 *Drying Pans or Dishes*, (for example, aluminum tins, porcelain dishes, glass weighing pans), two per waste, suitable to the waste being tested and the instructions given in **9.2**.

5.4 *Drying Oven*—Any thermostatically controlled drying oven capable of maintaining a steady temperature of ± 2 °C in a range of 100 to 110 °C.

5.5 *Desiccator*, having a capacity to hold the drying pans described in **5.3** and the crucibles described in **5.16**.

5.6 *Laboratory Balance*, capable of weighing to 0.1 g.

5.7 *Erlenmeyer Flask*, 2-L capacity, equipped with a magnetic stir bar.

5.8 *Magnetic Stir Plate*.

5.9 *Graduated Cylinder*, 1 or 2-L capacity.

5.10 *Pipet*, 1-mL capacity.

5.11 *Volumetric Flask*, 1-L capacity.

5.12 *Pipet*, 10-mL capacity. (Various other sized pipets, including micropipets, may be necessary for **9.3.2**.)

5.13 *pH Meter*—Any pH meter with a readability of 0.01 units and an accuracy of ± 0.05 units at 25 °C.

5.14 *Carboy-Type Container*, with spigot, 20 to 50-L capacity, of a composition suitable to the nature of the analyses to be performed (see Practices **D3370**).

5.15 *Large Glass Funnel*.

5.16 *Crucibles*, porcelain, 20-mL capacity each, two per waste.

5.17 *Wash Bottle*, 500-mL capacity.

5.18 *Agitation Equipment*, of any type that rotates the extraction vessel in an end-over-end fashion at a rate of 30 ± 2 r/min such that the axis of rotation is horizontal and it passes through the center of the bottle (see **Fig. 1**).

5.19 *Pressure Filtration Assembly*—A pressure filtration device using pressure regulated compressed gas of a composition suitable to the nature of the analyses to be performed and equipped with a 0.45 or 0.8- μ m pore size filter (see **Note 7**).

5.20 *Extraction Vessels*, cylindrical, wide-mouth, of a composition suitable to the nature of the waste and analyses to be performed, constructed of materials that will not allow sorption of the constituents of interest, and sturdy enough to withstand the impact of the falling sample fragments. The size of the container should be selected so that the sample plus extraction fluid occupy approximately 95 % of the container. The containers must have watertight closures.

³ Available from U.S. Government Printing Office, Washington, DC 20402. Request Publication Number 955-001-00000-1.

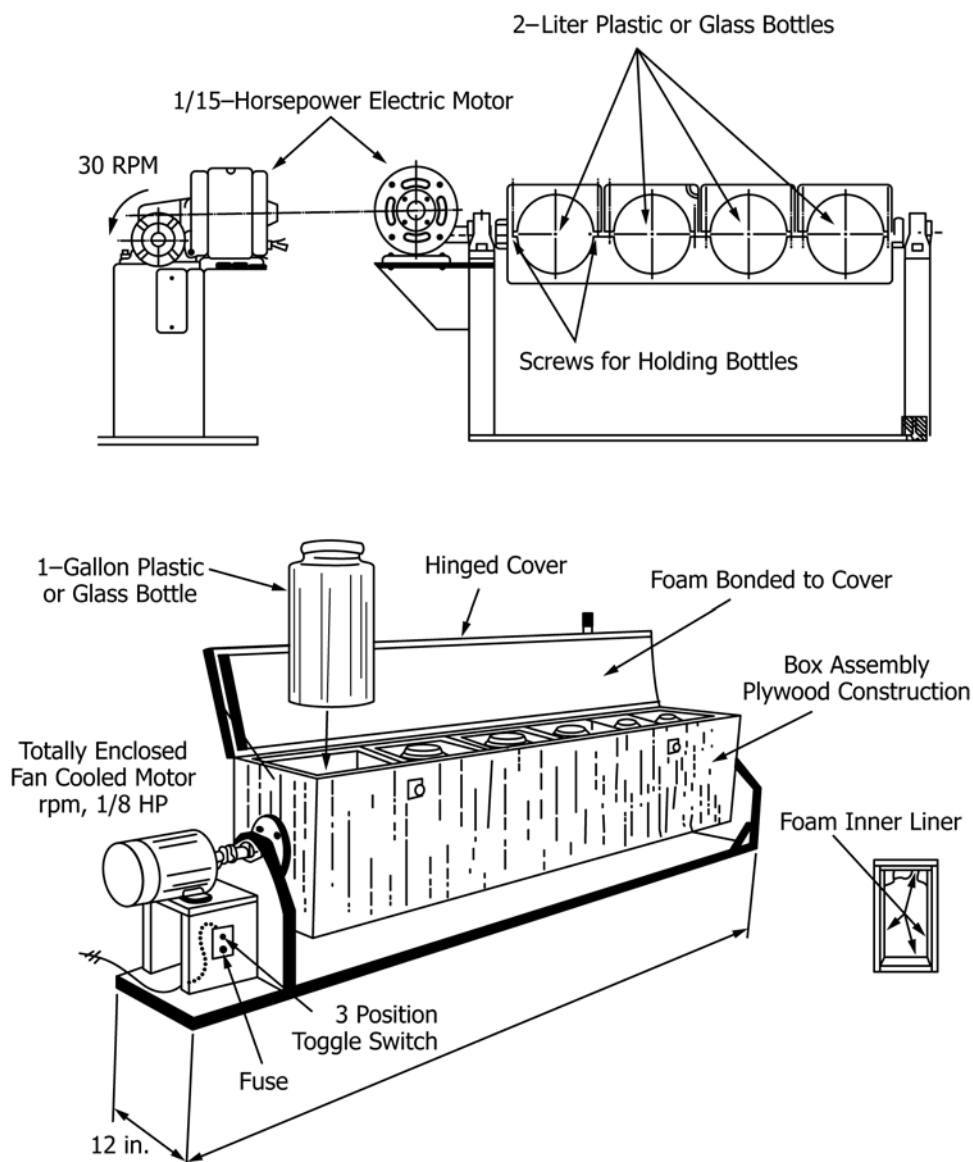

FIG. 1 Extractors

5.20.1 Extraction vessels should be cleaned in a manner consistent with the analyses to be performed (see Section 13 of Practices D3370).

6. Reagents

6.1 *Purity of Reagents*—Reagent grade chemicals shall be used in all tests. Unless otherwise indicated, it is intended that all reagents shall conform to the specifications of the Committee on Analytical Reagents of the American Chemical Society, where such specifications are available.⁴ Other grades may be

used, provided it is first ascertained that the reagent is of sufficiently high purity to permit its use without lessening the accuracy of the determination.

6.2 *Purity of Water*—Unless otherwise indicated, references to water shall be understood to mean Type IV reagent water at 18 to 27 °C conforming to Specification D1193. The method by which the water is prepared, that is, distillation, ion exchange, reverse osmosis, electrodialysis, or a combination thereof, should remain constant throughout testing.

6.3 *Sulfuric Acid/Nitric Acid Solution*—A 60/40 weight percent (weight %) mixture prepared using 95 to 98 weight % sulfuric acid and 69 to 71 weight % nitric acid. (See 9.3 for instructions on the preparation of this solution.)

⁴ *Reagent Chemicals, American Chemical Society Specifications*, American Chemical Society, Washington, DC. For suggestions on the testing of reagents not listed by the American Chemical Society, see *Analar Standards for Laboratory Chemicals*, BDH Ltd., Poole, Dorset, U.K., and the *United States Pharmacopeia and National Formulary*, U.S. Pharmacopeial Convention, Inc. (USPC), Rockville, MD.